

instructions

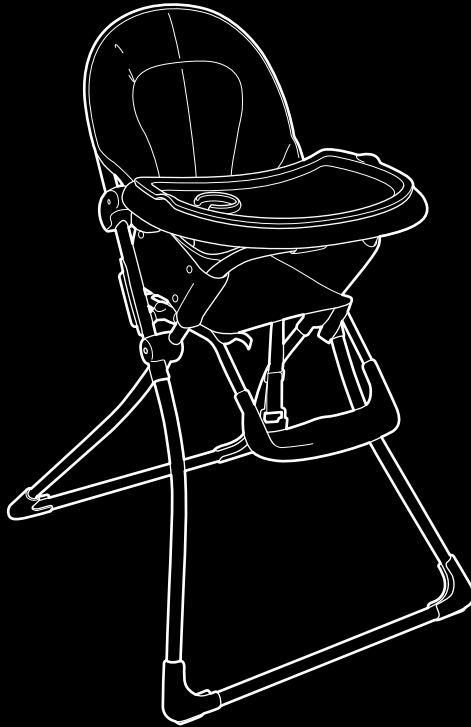

bon bon highchair

HC047-V1/06/06
© Mamas & Papas (Holdings) Ltd. 2006

IMPORTANT: Please read instructions carefully
and keep for future reference

Mamas & Papas

BON BON HIGHCHAIR

IMPORTANT: READ CAREFULLY AND RETAIN FOR FUTURE REFERENCE

- Do not discard any packaging until you have all the components.
- Read the instructions before constructing the product then follow them step by step.

COMPONENTS

Seat

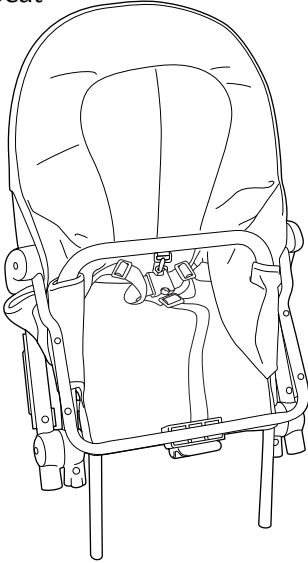

Tray

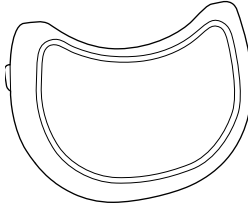

Tray insert

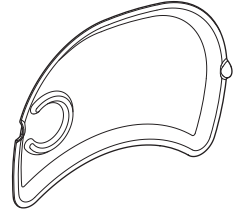

Screws

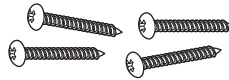

Footrest

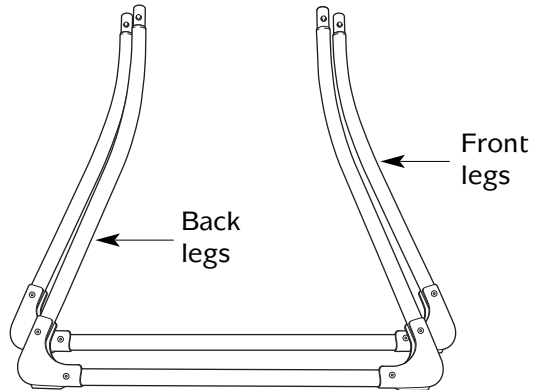
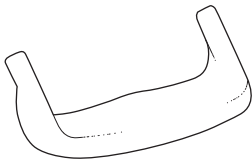

TOOLS NEEDED

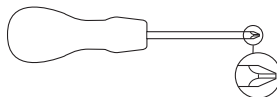

Cross-head
screwdriver

ATTACHING THE TRAY

Position the seat unit flat on a level work surface with the back of the seat facing down.

Position the tray face down on the front of the seat, then rotate the tray frame on the seat unit over the underside of the tray.

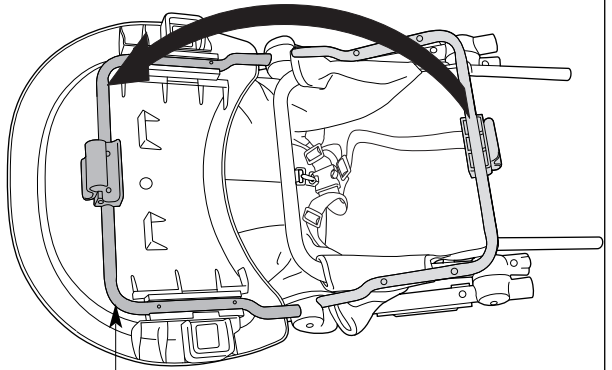

Tray frame

Align the lugs on the underside of the tray with the holes in the tray frame and slot them together.

Secure the tray to the tray frame using the four screws provided.

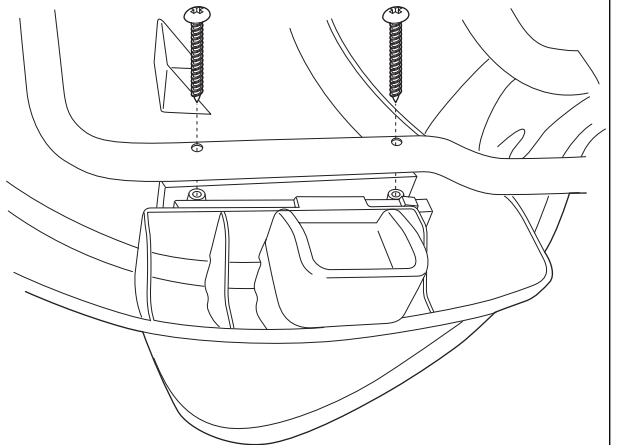

ATTACHING THE FOOTREST

Position the seat and tray unit flat on a level work surface with the tray facing down.

Slot the footrest onto the ends of the metal frame.

Depress the two locking buttons on the frame. Push the footrest onto the frame until the buttons lock into the holes on the footrest.

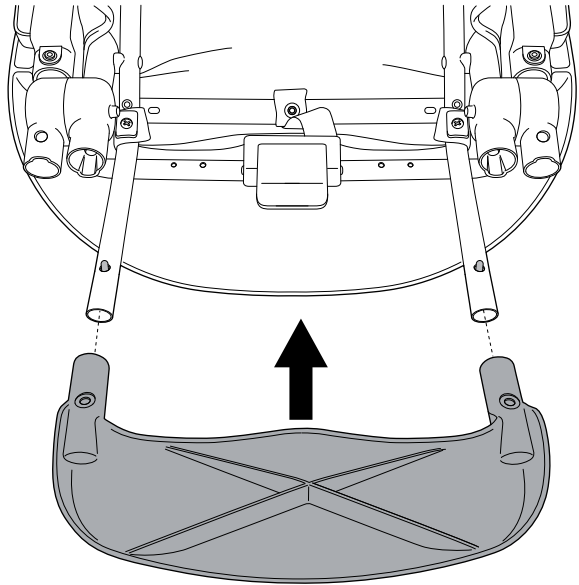

Ensure that the locking buttons are correctly engaged. The locking buttons must protrude through the holes in the footrest.

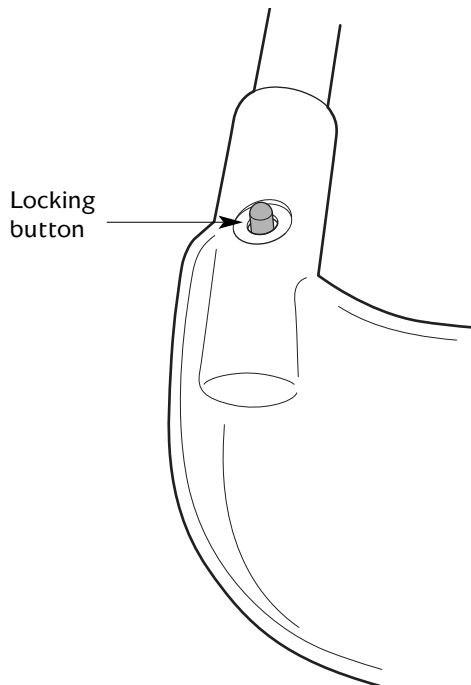

ATTACHING THE FRONT LEGS

Slot the front legs into the outer holes in the plastic mouldings.
Ensure that the buttons on the front legs are aligned with the holes in the plastic mouldings.
Push the front legs in until the locking buttons protrude through the holes in the plastic mouldings.

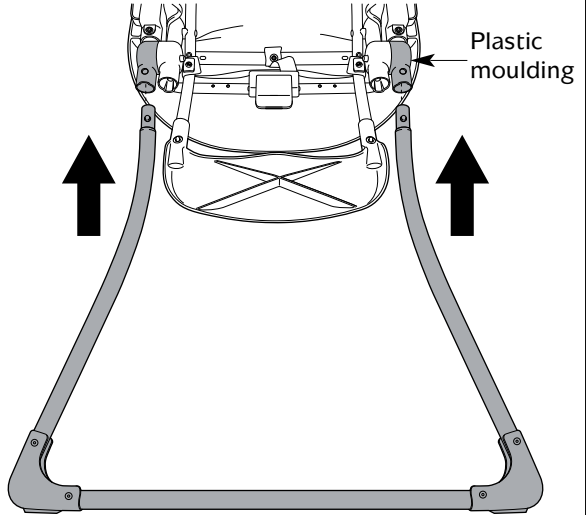

ATTACHING THE REAR LEGS

Slot the rear legs into the inner holes in the plastic mouldings.
Ensure that the buttons on the rear legs are aligned with the holes in the plastic mouldings.
Push the rear legs in until the locking buttons protrude through the holes in the plastic mouldings.

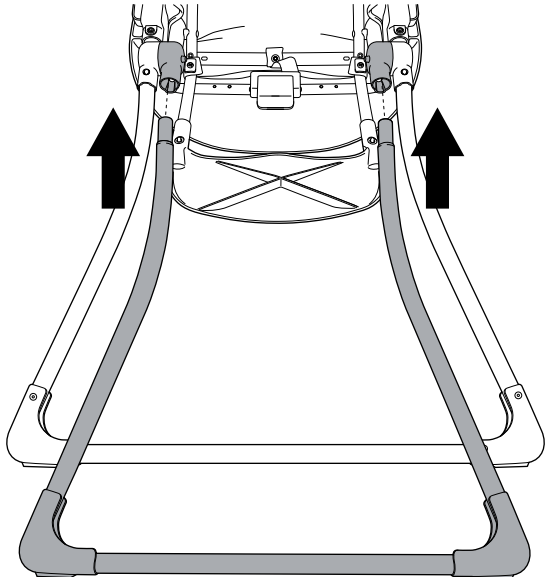

OPENING THE HIGHCHAIR

Stand the highchair upright.

Lift the tray up then pull the front and rear legs away from each other.

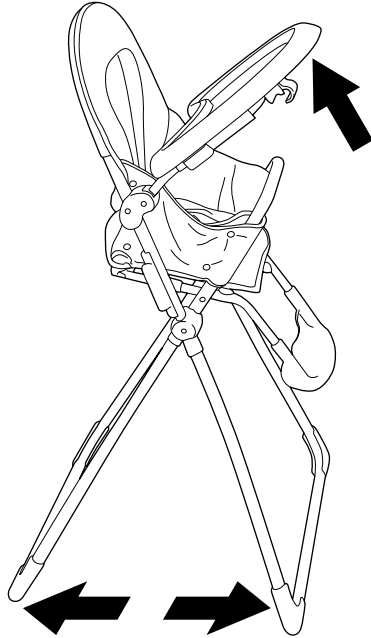

Lower the tray on to the front section of the frame.

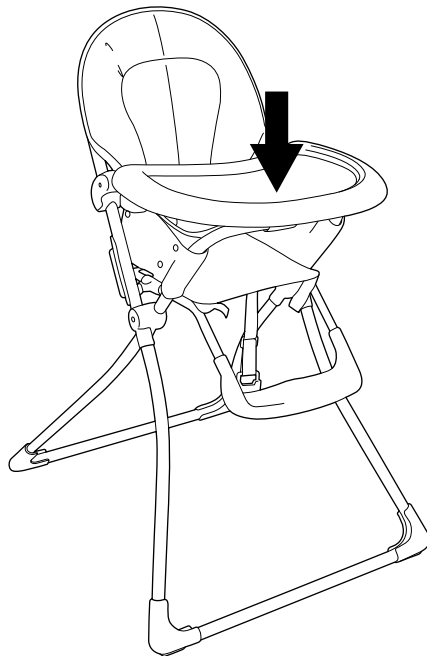

LOCKING THE TRAY IN POSITION

Push the frame lock under the tray down over metal frame.

The highchair is now locked in the open position and ready for use.

Ensure that the frame lock is fully engaged before placing your child in the highchair.

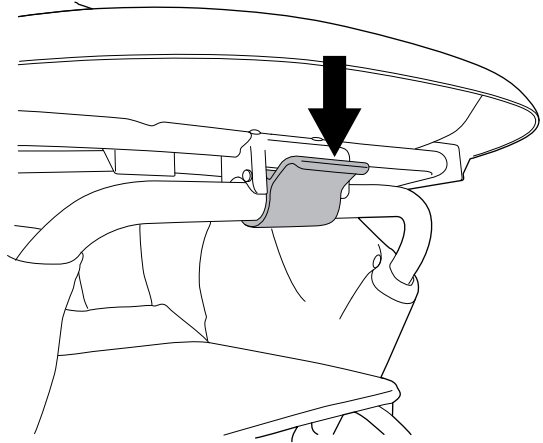

USING THE FEEDING TRAY INSERT

Your highchair is supplied with a feeding tray insert.

Simply slot the tray insert into the highchair's tray.

When your child has finished eating the insert can be removed and cleaned without having to remove the child from the highchair.

Note: Always remove the insert before folding the highchair.

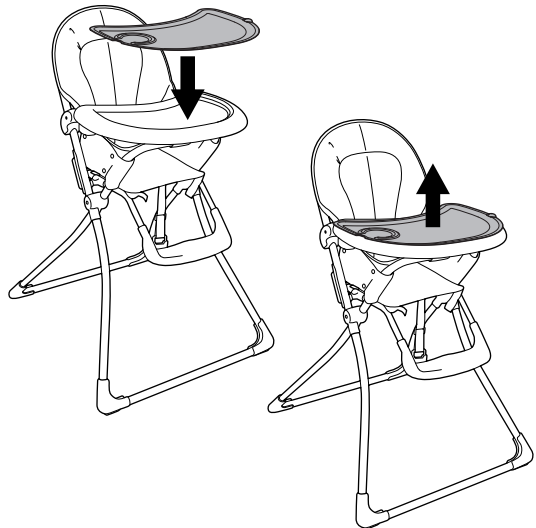

OPERATING THE HARNESS

Locking the harness:

Push the tongues on the ends of the waist strap into the buckle.

The harness will automatically lock when the tongues have been fully pushed in.

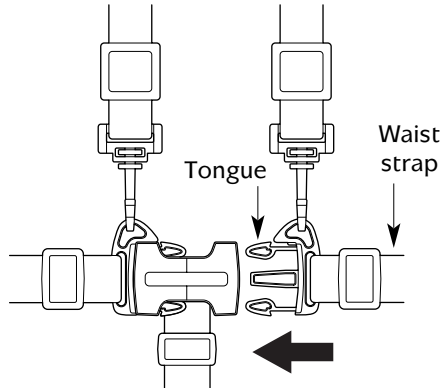

Adjusting the length of the harness:

Slide the buckles on the waist strap and shoulder straps forwards or backwards until the desired length is reached.

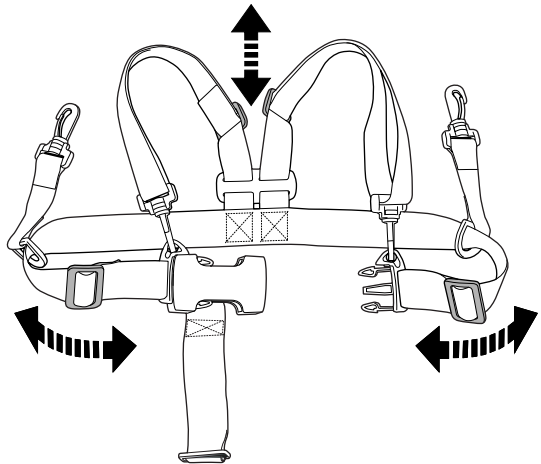

Unlocking the harness:

Squeeze the tongues together on one end of the waist strap **1** and then slide them out of the buckle **2**. Your child can now be removed from the highchair.

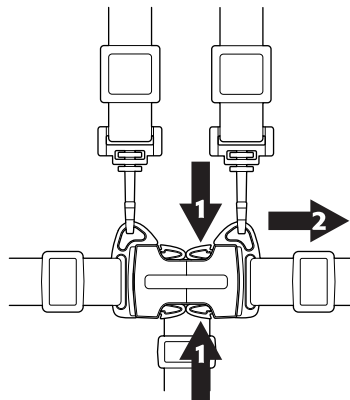

ADJUSTING THE TRAY

Locate the two tray adjustment handles located on the sides of the tray.

Pull both of them out then slide the tray into the desired position. Release the adjustment handles to lock the tray into one of the four positions.

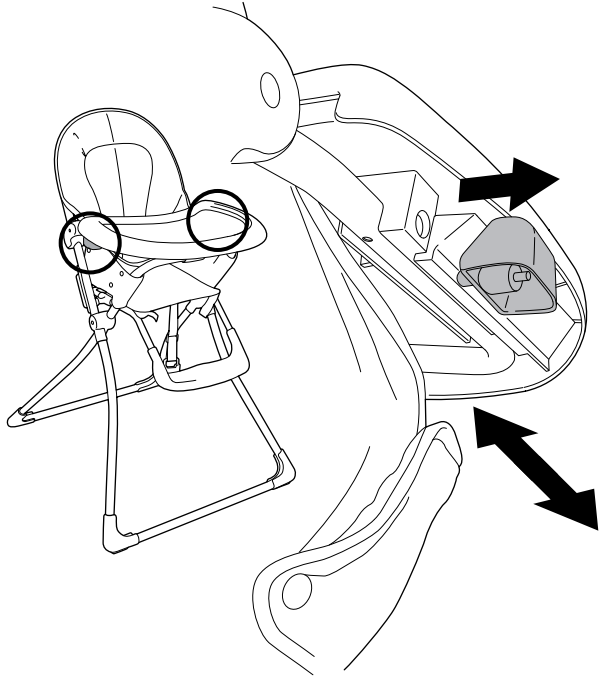

REMOVING THE FABRIC COVER

Unfasten the four press studs used to secure each fabric cover on either side of the highchair.

Use a cross-head screwdriver to remove the four screws and the four square washers. Slide the fabric cover from the backrest.

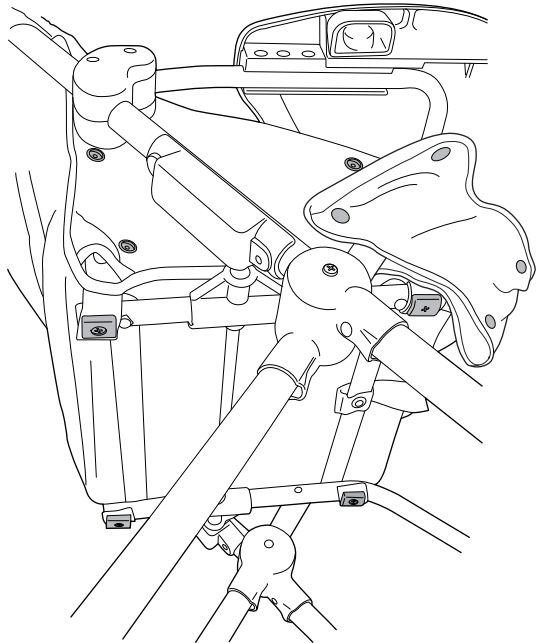

FOLDING THE HIGHCHAIR

To disengage the frame lock, lift the tab on the bottom lock upwards.

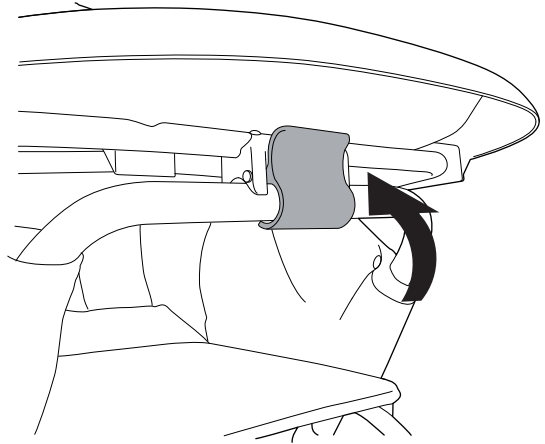

Lift the tray section upwards from the frame.

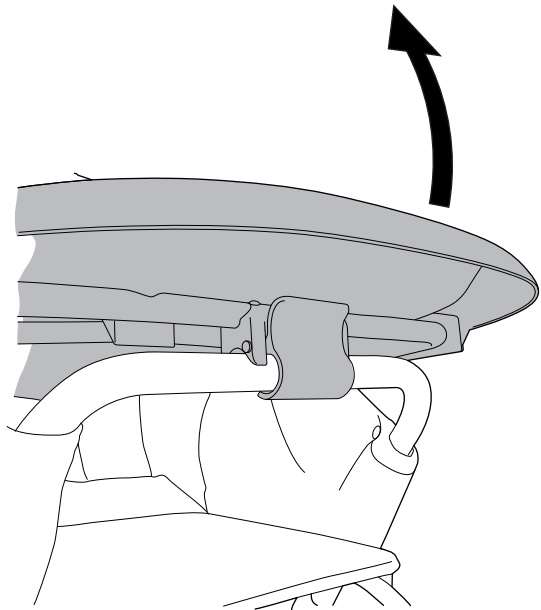

FOLDING THE HIGHCHAIR

Lift the tray clear of the frame then pull the front and rear legs together.

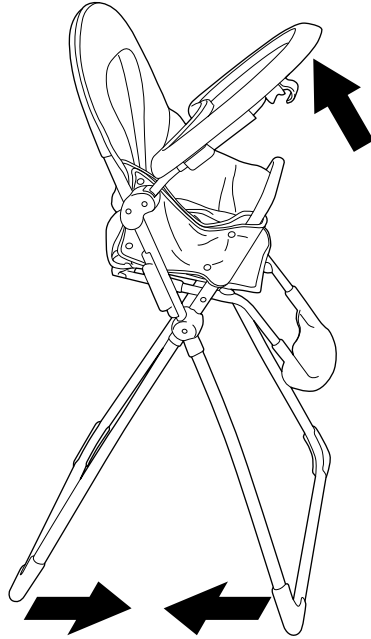

Lower the tray over the footrest.

The legs and the footrest can be removed for compact storage. Depress the locking buttons used to secure the legs and footrest to the frame, then pull to separate the components.

Store the components out of the reach of children.

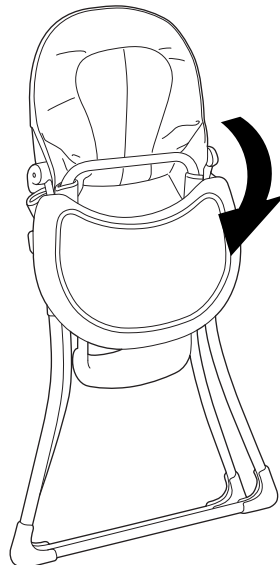

INSTRUCTIONS FOR SAFE USE

- **WARNING: A CHILD'S SAFETY IS YOUR RESPONSIBILITY.**
- **DO NOT LEAVE YOUR CHILD UNATTENDED.**
- The correct use and maintenance of your highchair will ensure it gives long and trouble-free use. When somebody else is using your highchair ensure they know how to use it, especially opening and folding, and the use of the safety locks.
- Suitable for children aged between 6 months to 3 years old. Do not use the highchair before the child can sit up by itself.
- Always use a safety harness. The child should be harnessed in at all times. Ensure that the harness is correctly adjusted, providing a snug fit around your child. .
- Ensure that all hazards such as small objects, sharp or hot items, or electrical flexes are kept out of your child's reach.
- Always ensure the highchair is on a level stable surface before use.
- Always ensure your child is clear of moving parts before making adjustments.
- Exposed edges of PVC covers are often the first to wear. Remember this as you transport, handle and store your highchair.
- Check your highchair regularly, particularly safety locks, harness and 'D' rings for wear, security and performance. No lubrication is necessary.
- Do not use the highchair if any part is broken, torn or missing.
- Do not use replacement parts that are not recommended or supplied by Mamas & Papas. Non-approved parts may render the repair or highchair unsafe.
- Do not use the highchair unless all components are correctly fitted and adjusted.
- Do not place your highchair in close proximity to an open fire or other sources of strong heat, such as radiators, electric or gas fires.

CLEANING:

Clean your highchair and tray insert with a damp cloth or sponge and mild detergent. Do not use abrasives or bleach.



AFTER SALES SERVICE: If you need assistance, spare parts or you are unhappy with any aspect of the goods please contact **Customer Services** on: **0870 8307700**, or e-mail us at: customer.services@mamasandpapas.com
Visit our website at www.mamasandpapas.com for the latest product information.

ALL OUR PRODUCTS ARE MADE FROM THE FINEST QUALITY MATERIALS AND ARE MANUFACTURED UNDER THE STRICTEST QUALITY CONTROLS

We guarantee all our products or part thereof, for a period of six months from the date of delivery to the consumer against faulty manufacture. This guarantee is not effective against damage caused as a result of incorrect usage of the product or accidental damage. This in no way affects your statutory rights.

GUARANTEE

To validate this guarantee, fill in this coupon and return to: **Mamas & Papas, Colne Bridge Rd, Huddersfield, HD5 0RH**
Alternatively, call our Guarantee Registration Line on: **01484 438225** or visit our website: www.mamasandpapas.com

Title (Mr/Mrs/Miss/Ms) First name Surname
 Address
 Postcode
 Daytime Tel. No. Email
 Baby's due date/date of birth
 Product purchased **Bon Bon Highchair**..... Purchase date Price

If you would like to receive further information regarding new products, promotions and special offers from Mamas & Papas please tick the boxes indicating your preferred method(s) of contact. Post ; Email .

If you would like to receive information from carefully selected 3rd parties please tick the boxes indicating your preferred method(s) of contact. Post ; Email .